

LG12864F-DW-TP

128 x 64 dots + white led backlight + touch panel

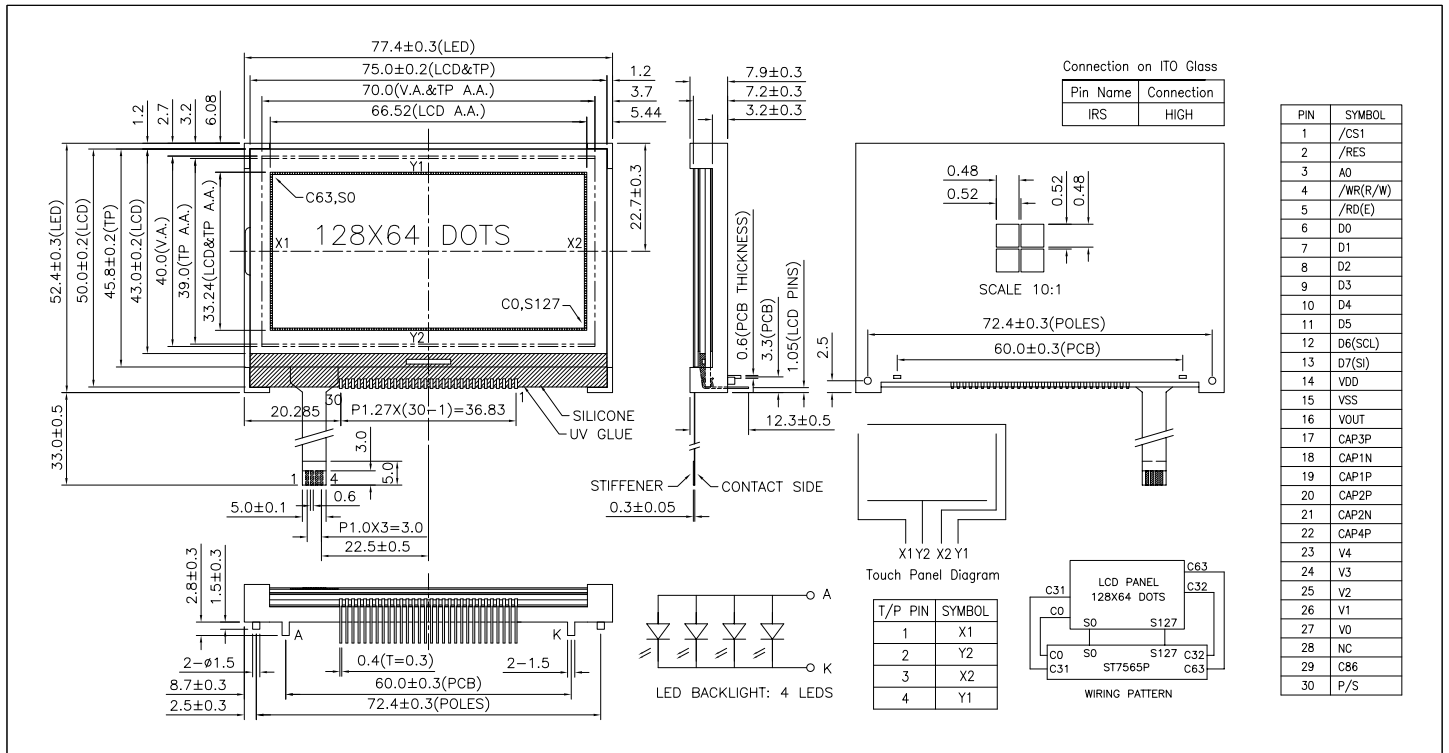

ABSOLUTE MAXIMUM RATINGS

Item	Symbol	Min.	Max.	Unit
Supply Voltage(Logic)	V _{DD} - V _{SS}	-0.3	3.6	V
Supply Voltage(LCD)	V _{OUT} - V _{SS}	-0.3	14.5	V
Input Voltage	V _I	-0.3	V _{DD} + 0.3	V
Operating Temp.	T _{opr}	-20	70	°C
Storage Temp.	T _{stg}	-30	80	°C

MECHANICAL DATA

Item	Nominal Dimensions	Unit
Module Size (W x H x T)	77.4 x 52.4 x 12.3	mm
Viewing Area (W x H)	70.0 x 40.0	mm
Dot Pitch (W x H)	0.52 x 0.52	mm
Dot Size (W x H)	0.48 x 0.48	mm
Weight	Approx. 45	g

ELECTRICAL CHARACTERISTICS (V_{DD}=2.4V to 3.3V)

Item	Symbol	Test Condition	Min.	Typ.	Max.	Unit
Input High Voltage	V _{IH}	--	0.8V _{DD}	--	V _{DD}	V
Input Low Voltage	V _{IL}	--	0	--	0.2V _{DD}	V
Output High Voltage	V _{OH}	I _{OH} = -0.1mA	0.8V _{DD}	--	V _{DD}	V
Output Low Voltage	V _{OL}	I _{OL} = 0.1mA	0	--	0.2V _{DD}	V
Supply Current	I _{DD}	V _{DD} = 3.0V	--	0.5	1.2	mA
LCD Driving Voltage	V ₀ - V _{SS}	T _a =25°C	--	9.0	--	V

PIN CONNECTIONS

Pin	Symbol	Level	Function
1	/CS1	L	Chip selection signal. Active "L"
2	/RES	L	Reset signal. Active "L"
3	A0	H/L	H:Display data L:Instruction code
4	/WR(R/W)	H/L	/WR for 80 MPU, R/W for 68 MPU
5	/RD(E)	H/L	/RD for 80 MPU, E for 68 MPU
6-13	D0-D7	H/L	Data bus line
14	V _{DD}	2.4-3.3V	Power supply for logic and booster
15	V _{SS}	0V	GND
16	V _{OUT}	--	DC/DC voltage converter output
17	CAP3P	--	Capacitor 3 positive connection
18	CAP1N	--	Capacitor 1 negative connection
19	CAP1P	--	Capacitor 1 positive connection
20	CAP2P	--	Capacitor 2 positive connection
21	CAP2N	--	Capacitor 2 negative connection
22	CAP4P	--	Capacitor 4 positive connection
23-27	V4-V0	--	Power supply for LCD drive
28	NC	--	No connection
29	C86	H/L	H: 6800 MPU L: 8080 MPU
30	P/S	H/L	H: Parallel mode L: Serial mode

BLOCK DIAGRAM

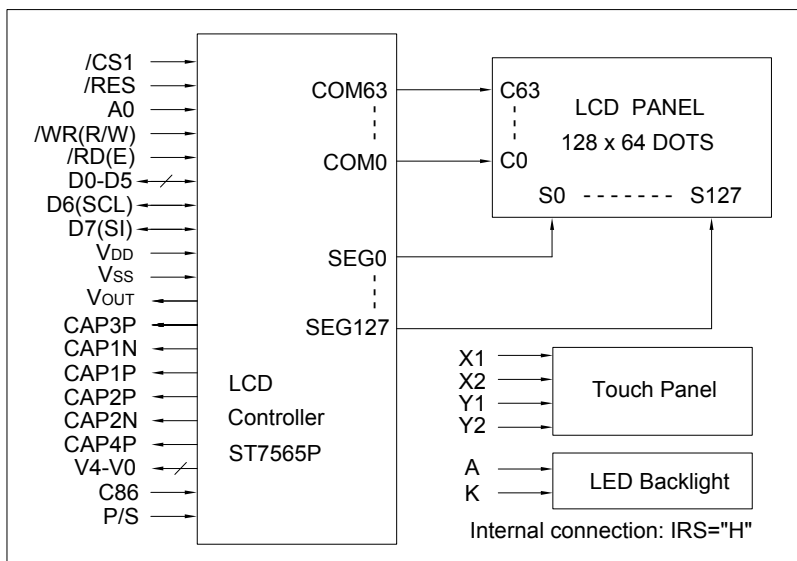

LED BACKLIGHT SPECIFICATIONS (T_a=25°C)

Item	Symbol	Typ.	Max.	Unit
Forward Voltage	V _f	3.1	3.3	V
Forward Current	I _f	60	--	mA
LED Color		White		