

LG122321 122 x 32 dots

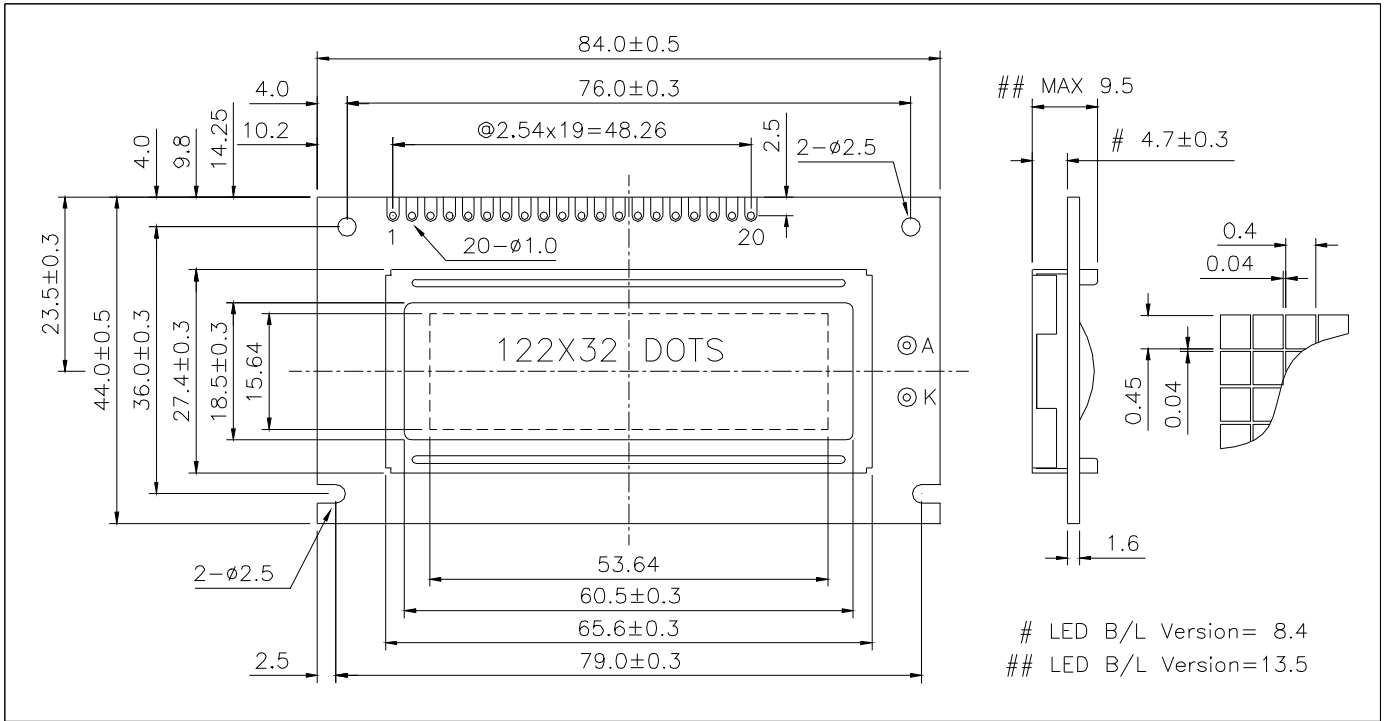

ABSOLUTE MAXIMUM RATINGS

Item	Symbol	Min.	Max.	Unit
Supply Voltage(Logic)	V _{DD} - V _{SS}	-0.3	7.0	V
Supply Voltage(LCD)	V _{DD} - V _O	-0.3	13.5	V
Input Voltage	V _I	-0.3	V _{DD} + 0.3	V
Operating Temp.	T _{opr}	-20	70	°C
Storage Temp.	T _{stg}	-20	80	°C

MECHANICAL DATA

Item	Nominal Dimensions	Unit
Module Size (W x H x T)	84.0 x 44.0 x 9.5/13.5	mm
Viewing Area (W x H)	60.5 x 18.5	mm
Dot Pitch (W x H)	0.44 x 0.49	mm
Dot Size (W x H)	0.40 x 0.45	mm
Weight (Reflective/LED)	Approx. 30 / 40	g

ELECTRICAL CHARACTERISTICS (V_{DD}=5V±0.25V)

Item	Symbol	Test Condition	Min.	Typ.	Max.	Unit
Input High Voltage	V _{IH}	--	2.0	--	V _{DD}	V
Input Low Voltage	V _{IL}	--	-0.3	--	0.8	V
Output High Voltage	V _{OH}	I _{OH} = -3.0mA	2.4	--	V _{DD}	V
Output Low Voltage	V _{OL}	I _{OL} = 3.0mA	0	--	0.4	V
Supply Current	I _{DD}	V _{DD} = 5.0V	--	0.4	0.8	mA
LCD Driving Voltage	V _{DD} - V _O	T _a =25°C	--	6.5	--	V

PIN CONNECTIONS

Pin	Symbol	Level	Function
1	V _{SS}	0V	GND
2	V _{DD}	+5V	Power supply for logic
3	V _O	--	Operating voltage for LCD
4	A0	H/L	H : Data, L : Instruction code
5	/CS1	L	Chip selection for IC1, active "L"
6	/CS2	L	Chip selection for IC2, active "L"
7	CL	--	External clock input (2kHz)
8	/RD(E)	H/L	/RD for 80 MPU, E for 68 MPU
9	/WR(R/W)	H/L	/WR for 80 MPU, R/W for 68 MPU
10	DB0	H/L	Data bus line
11	DB1	H/L	
12	DB2	H/L	
13	DB3	H/L	
14	DB4	H/L	
15	DB5	H/L	
16	DB6	H/L	
17	DB7	H/L	
18	/RST	H/L	Reset, H>L:80 MPU, L>H:68 MPU
19	LEDA	+5V	Power supply for LED backlight
20	LEDK	0V	

BLOCK DIAGRAM

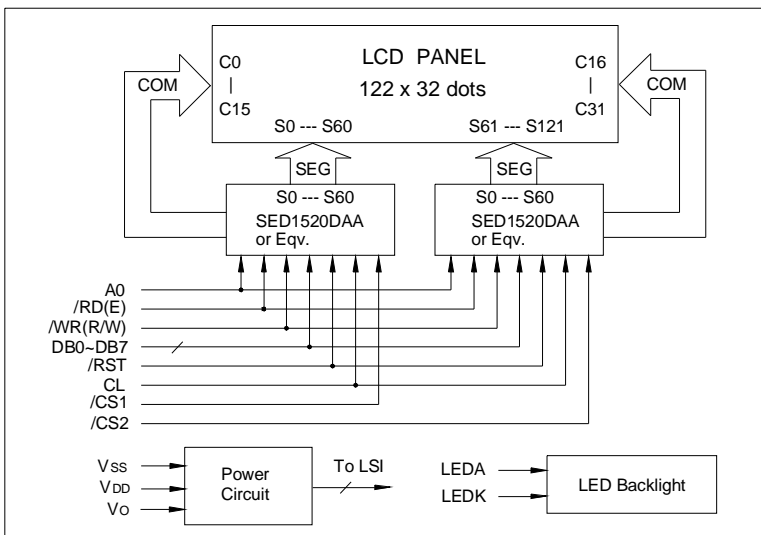

LED BACKLIGHT SPECIFICATIONS (T_a=25°C)

Item	Symbol	Typ.	Max.	Unit
Forward Voltage	V _f	4.1	4.3	V
Forward Current	I _f	120	--	mA
Emission Wave Length	λ _p	568	--	nm