

LG240644-DW

240 x 64 dots + white led backlight

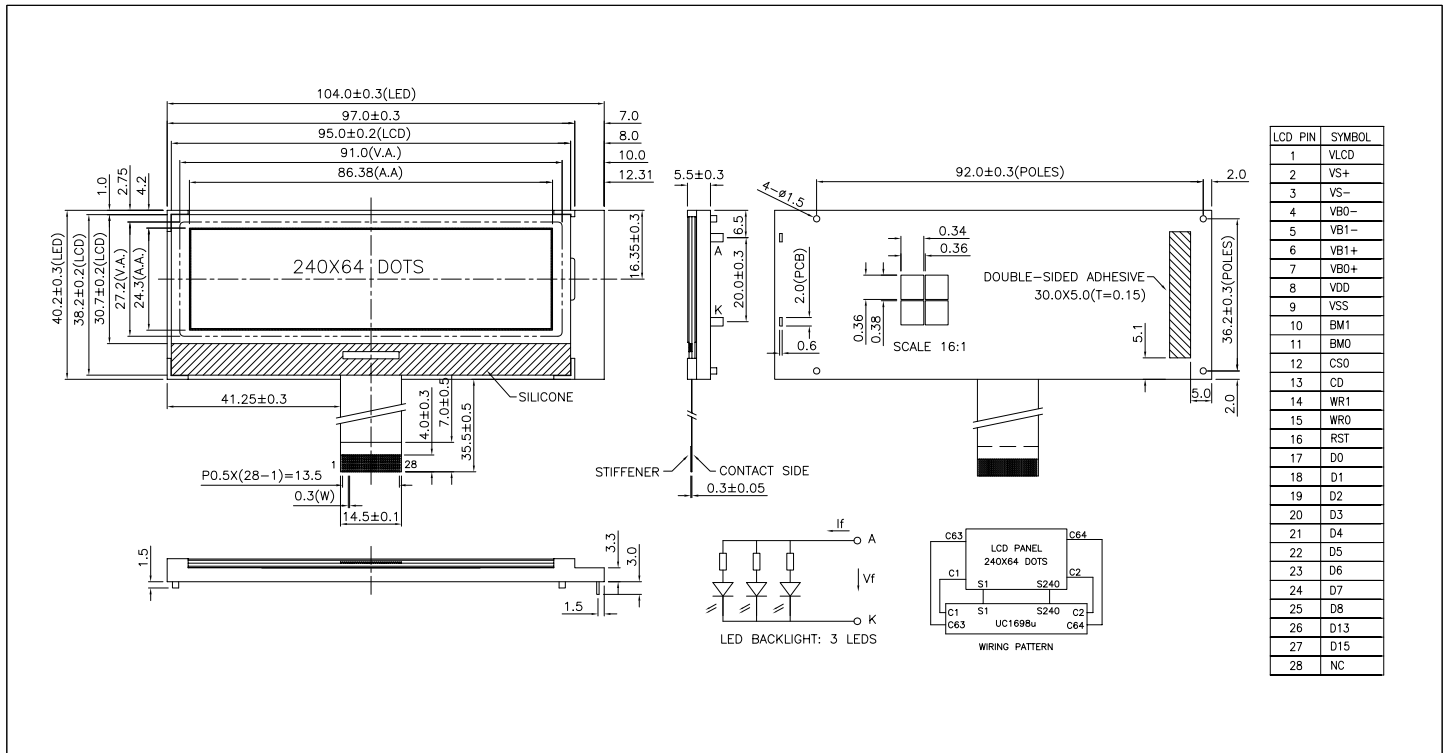

ABSOLUTE MAXIMUM RATINGS

Item	Symbol	Min.	Max.	Unit
Supply Voltage(Logic)	V _{DD} - V _{SS}	-0.3	4.0	V
Supply Voltage(LCD)	V _{LCD} - V _{SS}	-0.3	19.8	V
Input Voltage	V _I	-0.3	V _{DD} + 0.5	V
Operating Temp.	T _{opr}	-20	70	°C
Storage Temp.	T _{stg}	-30	80	°C

MECHANICAL DATA

Item	Nominal Dimensions	Unit
Module Size (W x H x T)	104.0 x 40.2 x 8.5	mm
Viewing Area (W x H)	91.0 x 27.2	mm
Dot Pitch (W x H)	0.36 x 0.38	mm
Dot Size (W x H)	0.34 x 0.36	mm
Weight	Approx. 30	g

ELECTRICAL CHARACTERISTICS (V_{DD}=2.7V to 3.6V)

Item	Symbol	Test Condition	Min.	Typ.	Max.	Unit
Input High Voltage	V _{IH}	--	0.8V _{DD}	--	V _{DD}	V
Input Low Voltage	V _{IL}	--	0	--	0.2V _{DD}	V
Output High Voltage	V _{OH}	--	0.8V _{DD}	--	V _{DD}	V
Output Low Voltage	V _{OL}	--	0	--	0.2V _{DD}	V
Supply Current	I _{DD}	V _{DD} = 3.3V	--	2.0	2.5	mA
LCD Driving Voltage	V _{LCD} -V _{SS}	T _a =25°C	--	13.2	--	V

PIN CONNECTIONS

Pin	Symbol	Level	Function
1	V _{LCD}	--	LCD driving voltage
2	VS+	--	LCD bias voltage
3	VS-	--	LCD bias voltage
4	VB0-	--	LCD bias voltage
5	VB1-	--	LCD bias voltage
6	VB1+	--	LCD bias voltage
7	VB0+	--	LCD bias voltage
8	V _{DD}	2.7-3.6V	Power supply for logic and booster
9	V _{SS}	0V	GND
10	BM1	H/L	Bus mode selection
11	BM0	H/L	Bus mode selection
12	CS0	L	Chip selection signal. Active "L".
13	CD	H/L	H:Display data L:Instruction code
14	WR1	H/L	/RD for 80 MPU; E for 68 MPU
15	WR0	H/L	/WR for 80 MPU; R/W for 68 MPU
16	RST	L	Reset signal. Active "L".
17-24	D0-D7	H/L	Data bus
25	D8	H/L	Serial data
26-27	D13,D15	H/L	Bus mode selection
28	NC	--	No connection

BLOCK DIAGRAM

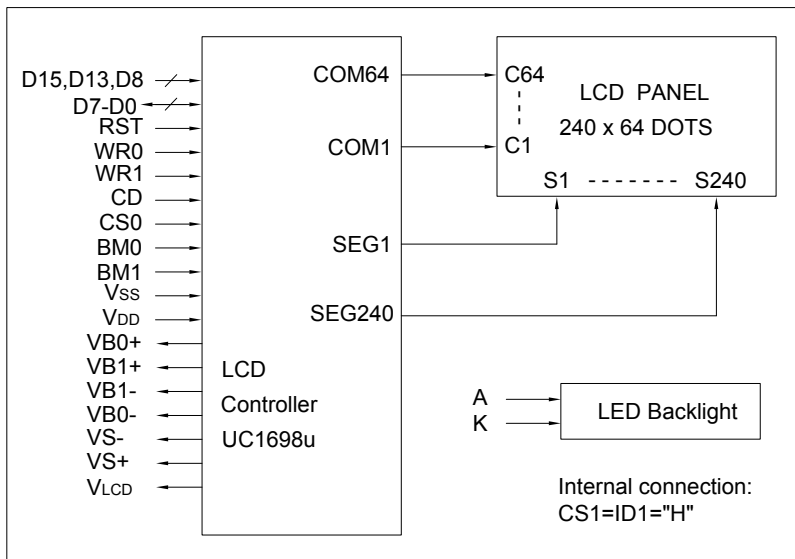

LED BACKLIGHT SPECIFICATIONS (T_a=25°C)

Item	Symbol	Typ.	Max.	Unit
Forward Voltage	V _f	3.1	3.3	V
Forward Current	I _f	45	--	mA
LED Color		White		