

FEATURES

- An ultra-fine CMOS process has been adopted for low power consumption in a design with no charge-pump.
- A small 24-pin QFN package (4*4mm / t=0.8mmMax / Lead pitch 0.4mm) has been adopted.
- All bridges can be driven simultaneously.
- Constant-Voltage control H-bridges Drive; Accuracy±5%(at CV DAC=4.0V)
- Constant-Current H-bridges Drive; Accuracy±5%(at CC DAC=200mV)
- A constant voltage value and a constant current value are set as arbitrary values by serial setup (4-bit).
- External resistance is unnecessary in order to change by Built-in DAC.
- Built-in thermal shutdown circuit.(shut: 150°C/return: 120°C/Hysterisis: 30°C)
- Built-in UVLO shutdown circuit.(shut: 1.8V/return: 2.0V/Hysterisis: 0.2V)
- Built-in CC mode weak excitation
- H-Bridge Drive Type/ON Resistance
 - CH1~3: CV/FS Ron=1.3Ω(TYP) at VM=5V, I=100mA (600mA MAX)
 - CH4: CC/CV/FS Ron=1.3Ω(TYP) at VM=5V, I=100mA (600mA MAX)
 - CH5: CC/Ron=1.3Ω(TYP) at VM=5V, I=100mA (600mA MAX)
- DAC
 - 4-bit composition
 - 1~4CH Constant-Voltage: 1.8~4.8V, 0.2V/bit
 - 4~5CH Constant-Current: 150~300mV, 10mV/bit
- Recommend Operating Condition
 - Power-supply voltage range: VCC: 2.7~3.6V, VM: 2.7~ 5.5V
 - Rated power-supply voltage: VCC: 3.3V, VM: 5.0V

BLOCK DIAGRAM

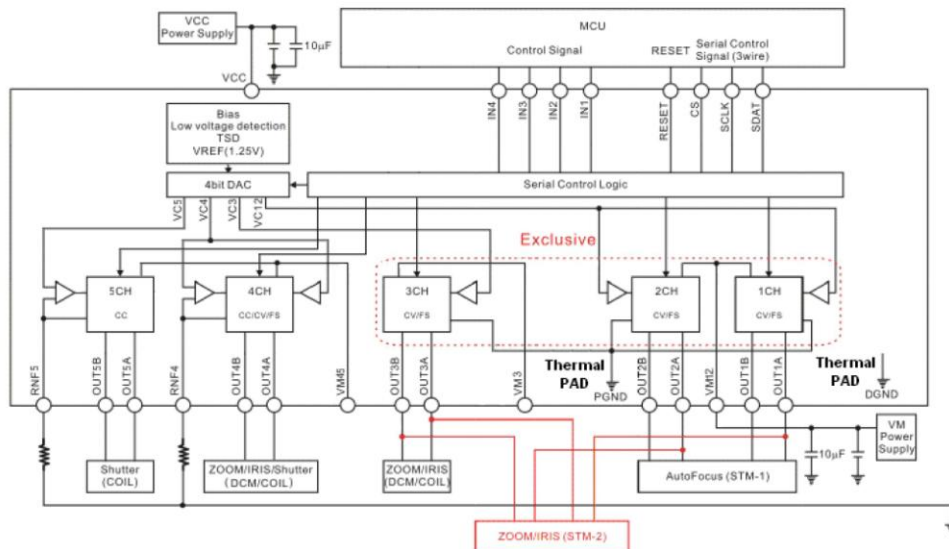

- Notes:
1. FS=Full-Swing
 2. CV=Constant-Voltage
 3. CC=Constant-Current